

**HD820Ⅱ**  
**HD820Ⅱ-LC**

||| FULLY HYDRAULIC EXCAVATOR |||

Bucket capacity: 0.45m<sup>3</sup> - 1.1m<sup>3</sup>(ISO)  
Engine output: 110kW/2,050min<sup>-1</sup>(ISO Net)  
Operating weight: 19,500kg (HD820Ⅱ)/  
20,300kg (HD820Ⅱ-LC)

**Dimensions**

(Unit: mm)

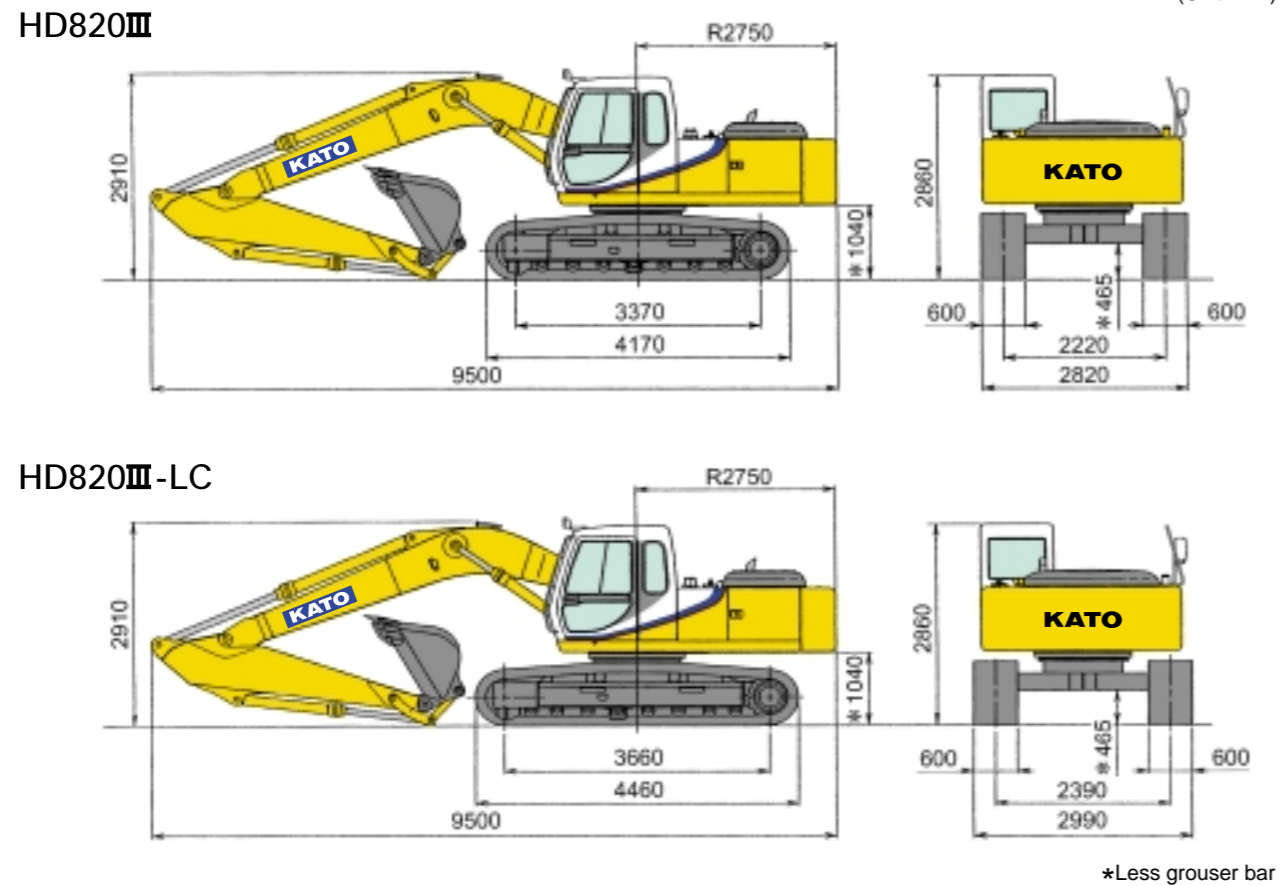

Address inquiries to :

NOTE : Illustrations may include optional equipment. KATO products and specifications are subject to improvements and changes without notice.



QUALITY & EXPERIENCE  
SINCE 1895

**KATO WORKS CO., LTD.**

9-37, Higashi-ohi 1-chome, Shinagawa-ku, Tokyo 140-0011 Japan.  
Tel. : Head Office Tokyo(03)3458-1111  
Overseas Marketing Department Tokyo(03)3458-1115  
Fax. : Tokyo(03)3458-1152  
URL <http://www.kato-works.co.jp>





# Gentle with Nature, Gentle with you Try and Feel the New Epoch of Performance



·Type K-version for demorishon work

·Standard version

·Type H-version for heavy duty work

## **Roomy and Comfortable Cabin**

- Auto air conditioner
- UV cut glass
- Ideal layout of each controlling gear
- Mono piece big & wide side window
- Anti-static-electricity fabric seat
- Wide range adjustable seating position

## **Powerful Engine**

Max Output: 110kW/2050min<sup>-1</sup>(ISO Net)  
with inter-cooler & turbo-charger

## **Low Noise Emission**

99dB(A)\*, sound power level

## **Low Engine Emission**

Complying with the latest  
emission control

## **Durable Cooling System**

- High performance radiator and  
aluminum oil cooler
- Easy access for cleaning.

## **Replacement Interval of Hydraulic Oil: 5,000 hours**

\*JIS Sound power level.



# Technical Specifications

## ENGINE

Model .....Mitsubishi 6D34-TLE2A, 4 cycle intercooler turbo charged diesel engine

Number of cylinders ..... 6

Bore & Stroke ..... 104mm x 115mm

Total displacement ..... 5.86 L

Rated output ..... 110kW/2,050min<sup>-1</sup> (ISO Net)

Max. torque .....580N·m/1,400min<sup>-1</sup> (ISO Net)

Compression ratio ..... 18.2:1

Combustion system .....Direct injection

Specific fuel consumption ..... 225g/kW-hour

Cooling system .....Pressurized water circulated by a centrifugal pump with thermostat

Lubrication system .....Pressurized oil fed by a gear pump through full-flow and bypass cartridge filter

Starter .....Electric, 24V-5kW

Generator.....Alternator, 24V-35A

Governor..... Mechanical

Air cleaner.....Dry type filter

## HYDRAULIC SYSTEM

Pumps .....Double variable piston pump and gear pump

Max. discharge flow ..... 2 x 235L/min

Max. discharge pressure ..... 31.4MPa

Max. discharge pressure (travel circuit only) ..... 32.9MPa

Oil filtration ..... Full-flow filter with replaceable element, drain cartridge filter, pilot line filter and suction strainer

Control valves ..... 5 + 4 section multiple control valves (with one free service circuit)

Pilot pump ..... Gear type

Oil cooler ..... Finned tube, forced ventilation

Pressure relief valves ..... Primary and secondary on each circuit

## CAB & CONTROLS

Type ..... All weather sound suppressed, 1,000mm wide pressed steel cab mounted on 6 point viscourse mounting.

Right hand lever ..... Controls the boom & bucket

Inner right hand lever (with foot pedal) ..... Controls the right hand track

Inner left hand lever (with foot pedal) ..... Controls the left hand track

Left hand lever ..... Controls the arm & swing

Pilot control ..... Travel, boom, arm, bucket and swing

Engine throttle ..... Electric "Accel dial"

Meter & gauges ..... Hour meter, water temperature and fuel level

Monitor display ..... Engine oil pressure, engine oil filter, hydraulic oil filter, hydraulic oil temperature, water temperature, water level, fuel level, battery charge, APC monitor and air cleaner.

Indicator lamps ..... Caution lamp & Engine preheater indicator lamp

Working lights ..... Provided on the boom left side and mounted on the frame

Lubrication chart ..... Inside the tool box



## SWING SYSTEM

Drive ..... Axial piston motor with shockless valve and reduction gear.

Brake ..... A hydraulic brake that locks automatically when the swing control lever is in the neutral position and a mechanical parking brake which is applied when the safety lock lever is pulled backwards, the engine is turned off or the swing control lever is in the neutral position.

Lubrication ..... Completely housed and grease bathed

Max. swing speed ..... 13.5min<sup>-1</sup>

Tail swing radius ..... 2,750mm

Min. front swing radius ..... 3,460mm

## BOOM, ARM AND BUCKET

Boom cylinders ..... Two, double acting

Bore & Stroke ..... 125mm x 1,315mm

Arm cylinder ..... One, double acting

Bore & Stroke ..... 135mm x 1,630mm

Bucket cylinder ..... One, double acting

Bore & Stroke ..... 120mm x 1,090mm

Lubrication ..... Grease nipples, with centralized greasing for remote points

Bucket digging force ..... 136kN (High power) ..... 144kN

Arm digging force ..... 99kN (High power) ..... 104kN

Note: High power can be used with STD arm and short arm

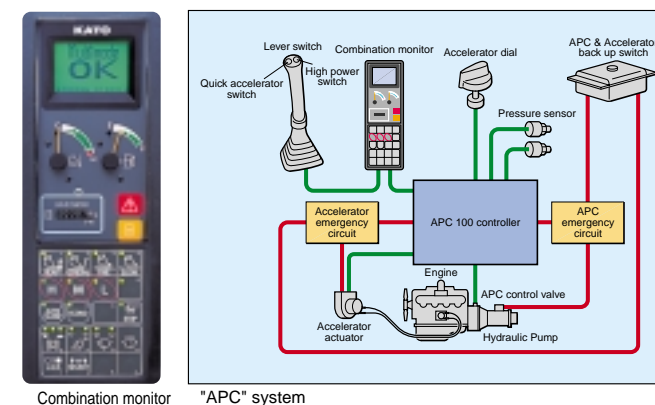

Combination monitor "APC" system

## SERVICE DATA

Fuel tank ..... 320 L

Cooling system ..... 23 L

Engine oil ..... 22 L

Track drives ..... 2 x 5 L

Swing drive ..... 5 L

Hydraulic oil tank (level) ..... 165 L (system) ..... 260 L

In standard figure, with the 2.93m arm, 600mm grouser shoes and 0.8m<sup>3</sup> ISO, bucket.

Operating weight ..... 19,500kg: HD820III  
20,300kg: HD820III-LC

Ground pressure ..... 43kPa: HD820III  
42kPa: HD820III-LC

## TRAVEL SYSTEM

Drive ..... Independent axial piston motor with reduction for each side

Brakes ..... Independent disk parking brake for each side, applied automatically when the travel levers are in the neutral position.

Track shoes ..... 46 each side HD820III  
49 each side HD820III-LC

Track adjustment ..... Grease cylinders with recoil springs

Lubrication ..... Sealed-for-life rollers and front idlers with floating seals

Travel speed ..... High 0 ~ 5.5km/h  
Medium 0 ~ 3.6km/h  
Low 0 ~ 2.5km/h

Gradeability ..... 70% (35°)

Max. drawbar pull ..... 174.6kN

Ground clearance (less grouser bar) ..... 465mm

Track length ..... 4,170mm HD820III  
4,460mm HD820III-LC



Fire wall

