

# HD-550 *EXCEED*

**Bucket capacity**

- CECE heaped : 0.26m<sup>3</sup> ~ 0.65m<sup>3</sup>
- PCSA, SAE heaped : 0.37yd<sup>3</sup> ~ 0.99yd<sup>3</sup>

**Engine output**

: 100PS / 2,000rpm (JIS, DIN)  
99HP (74kW) / 2,000rpm (SAE, Net)

**Gross weight**

: 14,500 kg (32,000 lbs) HD-550V<sub>II</sub>  
15,700 kg (34,600 lbs) HD-550V<sub>II</sub>-LC

**V<sub>II</sub> series**

**KATO**



**The widely acclaimed advanced excavator with exten**





**sive improvements to satisfy your expectation**





# Comfortable king size cab brighten up operating



• Tinted safety glass



• Crossbar eliminated for wide forward visibility



• Flat floor making access and cleaning easy



• One key system



• Safety monitor ensures safety





# environment



• King-size cab meets ISO international standard (940 mm)



• Long lever available



• Sturdy frame-structure prevents the engine cover from the damage



• Large tool box







# State-of-the-art technology feel the all advantages

## New "APC" computer system enables use of full engine power

■ An advanced new computer system developed by Kato, New "APC", controls pump output in line with work conditions and site demands. Engine and pump output are matched at optimum level in a ground-breaking system that exploits 100% of engine power.

## Economical "Auto Slow" system saves fuel consumption while waiting to dump

■ A few seconds after the lever is put into neutral, the fuel-saving "Auto Slow" system automatically drops the engine speed down to an idle. This reduces power loss while waiting to dump, thus cutting fuel waste and further improving overall economy. Noise is reduced, too. Auto Slow has three modes: On, Off and Econo mode

- **On mode:** Engine speed is automatically reduced; most effective when waiting to dump, etc,

- **Off mode:** Use the quick accelerator switch to drop speed to idle and then to restore its previous speed.

- **Econo mode:** Engine speed is set at the most efficient production/fuel consumption. The quick accelerator switch slows down to idle and restores the Econo speed as in Off mode.



## Six modes let you balance work load with fuel consumption and noise level

■ Changing the "APC" mode (H mode, M mode, L mode) lets the operator automatically control the load ratio on the engine. Econo mode additionally allows the engine speed to be reduced, further lowering fuel consumption and noise by another large step.

## Two-speed travel motor and travel boost system push this machine to the head of its class (5.5 kmh/3.4mph)

■ Two-speed travel motor and travel boost system give this machine the highest speed and traction force in its class. Operator can easily select the right travel speed to suit the requirements of the job.

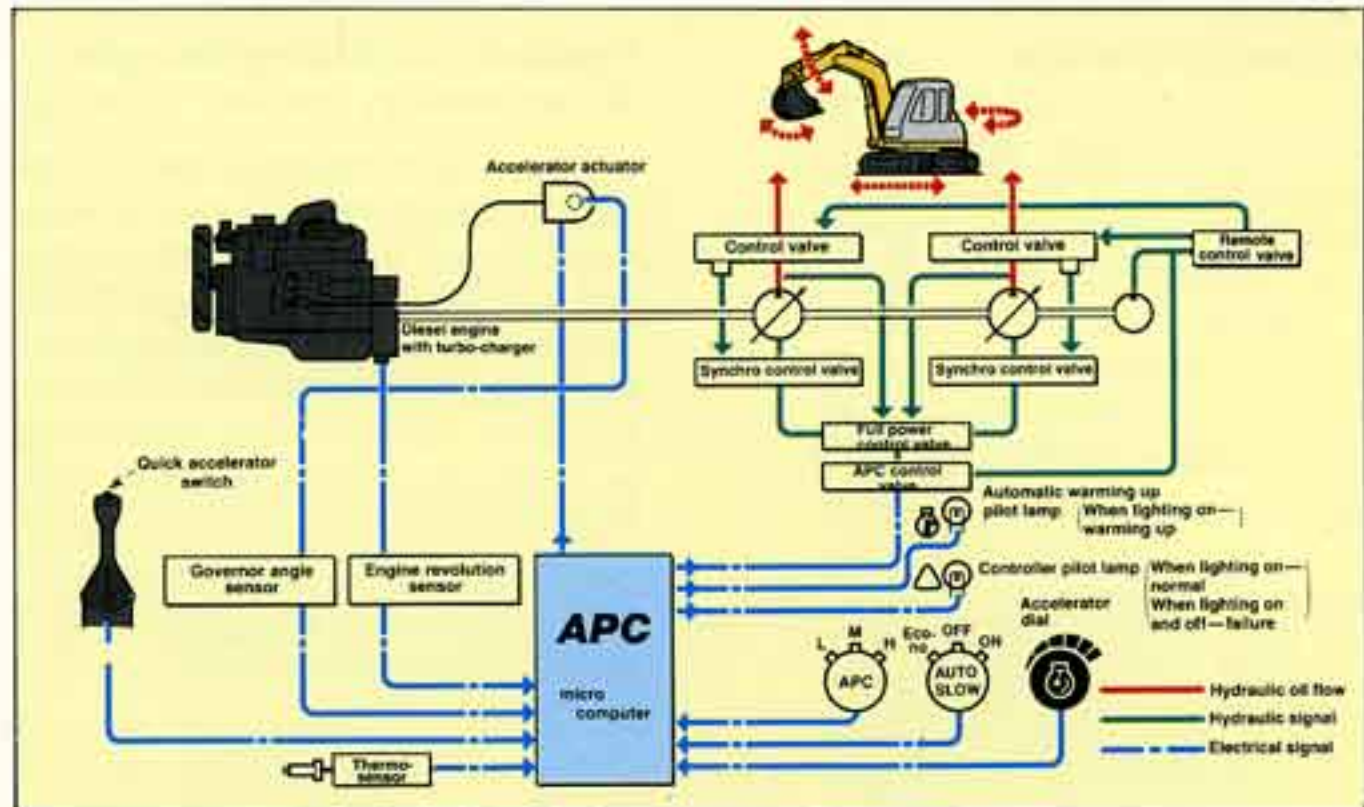

## Choose from big-job, fuel-efficiency and small-job modes

■ Choose from any one of three modes of "APC" control depending on the requirements of the job. Select the H mode (which makes maximum use of engine power), the M mode (which changes engine power without reducing engine rpm) or the L mode.

**H mode** (for greatest productivity): Ideal for jobs that involve lots of digging and earthmoving—enables you to get the work done faster for maximum productivity.

**M mode** (saves fuel): Greatly reduces fuel while keeping high productivity.

**L mode** (for precise operation): Optimum for precise jobs like grading, leveling and lifting at minimum fuel consumption.

- **H mode** for greatest productivity
- **M mode** for less fuel consumption
- **L mode** for precise operation



### H mode for greatest productivity



### M mode for less fuel consumption



### L mode for precise operation

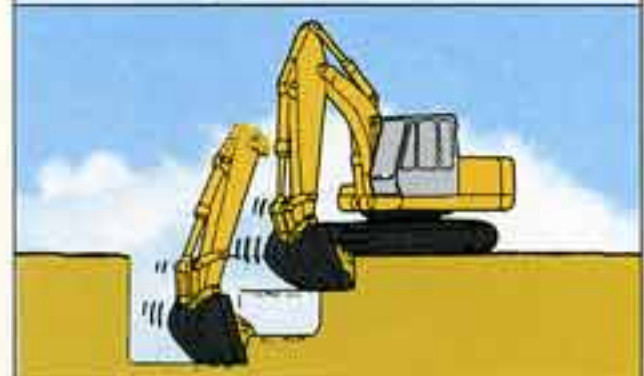

### High speed traveling long distance traveling

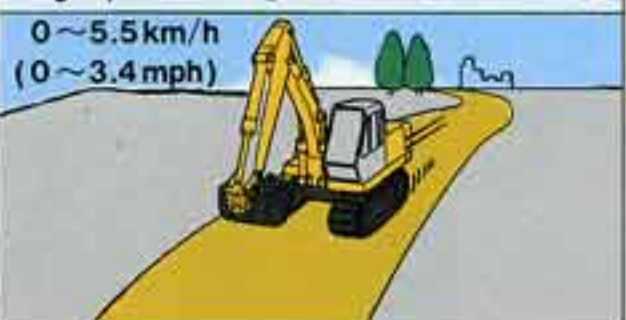

### Low speed traveling traveling on site, climbing up steep slopes or getting out of marshy land



- **High speed traveling** ..... long distance traveling
- **Low speed traveling** ..... traveling on site, climbing up steep slope or getting out of marshy land



## Wide operating range

■ Digs deeper, higher and wider than any machine in its class. This machine has a maximum digging depth of 6.06m (19' 11"), a maximum digging radius of 8.91m (29' 03"), a maximum vertical digging depth of 5.25m (17' 03"), and a maximum digging height of 8.71m (28' 07").

## Greatest digging force

■ Digging force is tops in its class: bucket digging force is 9.3t (20,500lb) and arm digging force 7.0t (15,400lb). This exceptional force makes the machine fast and effective even on tough digging jobs like clay and hard dirt.

## Smallest swing radius in machines of its kind—perfect for narrow road jobs

■ The minimum front swing radius is a 3.16m (10' 04") only. Combined with the rear swing radius of 2.47m (8' 01"), it gives the smallest swing radius of any machine of its size. Urban jobs like water and sewer line construction in tight spaces like tunnels or in crowded residential areas are a snap.



## Smooth fine control

■ Cushioning mechanism absorbs shocks in the arm cylinder and boom cylinder. The proved swing mechanism ensures the smooth swing without jerks.

## Synchro control system reduces energy waste

■ When the operating lever is in neutral, the pump flow rate is automatically set to a minimum to save fuel and the supply rate is matched to lever stroke. So loss through restriction and discharge from the control valve during inching operations or when in neutral position have been reduced.

## Straight travel system while compound operation

■ The machine can travel straight even while the compound operation of boom, arm, bucket and swing.

## High-power, low-fuel-consumption and low-noise direct-injection turbo-charged engine

■ Tenacious and reliable, the direct-injection turbo-charged engine is just the start of a thoughtful noise-reducing, fuel-efficient and high-power design. Combined with the New "APC" it creates the great productivity and low fuel costs.



## Innovative "Accel Dial" for engine speed control

■ Engine speed is controlled by finger-touch "Accel Dial" thanks to an electric servomotor. Combination with "Auto Slow" makes the engine control more advanced.

## Light-touch lever-control

■ Light touch servo control levers are employed for ease of operation. Both a wrist control lever and a long lever are available.

## Roomy wide cab for enhanced operator's comfort

■ A roomy wide cab features an ISO standard width of 940mm (3'1"). The tinted safety glass, all controls and instruments are ergonomically designed for optimum comfort. The fully reclining bucket type seat with forward/backward, vertical and recline angle adjustment is designed so that the operator will experience a minimum of fatigue, even when working long hours.

■ The cab structure is rubber-mounted on six positions. The compressed sound-proofing materials are also installed in the cab to isolate engine and other outside noise and vibration from the cab for the operator's comfort.

## Low noise design

■ A number of features have been incorporated to reduce noise, among them the quiet turbo-charged engine, a muffled engine room with a bottom cover, and plenty of sound-absorbing material applied to the engine cover for the low noise inside the cab and in the environment.

## Check machine condition at a glance

■ A safety monitor is provided for inspection prior to commencing work so that the operator can check the condition of the machine at a glance from the comfort of his seat. In the event of a fault, a red lamp lights and a buzzer sounds to warn the operator.





**New design makes maintenance simple**

- Tool box is large enough to accommodate tools, a grease can and etc, and the large fuel tank cuts down frequency of refuelling.
- The superstructure is provided with hand-rails and non-slip tapes for safety and easy access during inspections and maintenance.
- Just one key to start the engine as well as locking the cab, machine room and all other locations.
- Radiator net prevents from clogging and easy to slide upwards for easy maintenance.



**Sturdy frame-structure prevents the engine cover from the damage**

- The skirt of the superstructure is so designed, in the rounded, sturdy frame-structure, as to protect the engine cover from accidental contact and shocks.

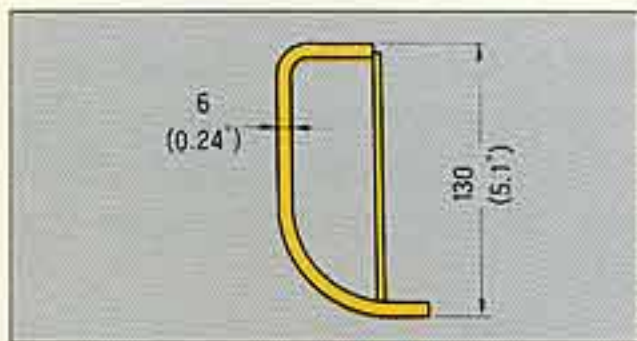

**Superstructure-undercover eases travel and work in rough terrain**

- The superstructure is provided with the undercover for easy travel and work in rough terrain.

**Handy centralized lubrication system**

- A remote lubrication system makes greasing of high area safe and easy.
- Dust seals and o-rings provided for the front attachment and bucket extend pin life and improve durability.



**Bucket clearance is easy to adjust**

- To adjust bucket clatter simply loosen the fitting bolts, remove the flange, add shims to the loose area and then re-tighten to eliminate the clatter.



**Sturdy, stable undercarriage**

- The travel motor is neatly housed inside the track frame with a cover. Sufficient ground clearance assisted by a traveling pipings cover and mud clogging prevention hole located underneath the carrier roller, ensures powerful travel without any fear of the damage even on ungraded land.



**Swing motor with parking brake ensures safety**

- Swing mechanical parking brake which prevents free swinging when traveling and on inclines.

**Safety lock lever**

- Safety lock lever prevents accidental misoperation when getting in and out of the cab.





# Technical Specifications



## ENGINE

Model .....	Mitsubishi 6D31T, 4 cycle turbo charged diesel engine
Number of cylinders.....	6
Bore & Stroke.....	100mm (3.9")×105mm (4.1")
Total displacement .....	4,948cc (302 in. <sup>3</sup> )
Rated output .....	100PS (74kW)/ 2,000rpm (JIS D1005-1986, DIN 6270B) 99HP (74kW)/2,000rpm (SAE J1349, Net)
Max. torque .....	38.8kgf·m/1,600rpm 281lbf·ft/1,600rpm
Compression ratio .....	16.5 : 1
Combustion system .....	Direct injection
Specific fuel consumption .....	160g/PS-hour 0.36lb/HP-hour, 218g/kW-hour
Cooling system.....	Pressurized water circulated by a centrifugal pump with thermostat
Lubrication system .....	Pressurized oil fed by a gear pump through full-flow and by-pass cartridge filters.
Starter .....	Electric, 24V–5kW
Generator.....	Alternator, 24V–30A
Governor.....	Mechanical
Air cleaner .....	Dry type filter



## TRAVEL SYSTEM

Spring-applied idlers protect the drives from shock. Adjust cylinder is provided for easy arrangement of the track tensioning. An all welded undercarriage frame gives clog-free clearance, and the drive motors are neatly housed inside the track frame. The crawler tracks with interchangeable shoes are supported by 7 lower rollers, 1 upper roller.  
(2 upper rollers for HD-550V<sub>II</sub>-LC)

Traveling motors .....	Independent axial piston motors with reduction for each side
Brakes.....	Independent disk parking brake for each side, applied automatically when the travel levers are in the neutral position.
Track shoes .....	45 each side HD-550V <sub>II</sub> 48 each side HD-550V <sub>II</sub> -LC
Track adjustment.....	Grease cylinders with recoil springs
Lubrication.....	Sealed-for-life rollers and front idlers with floating seals
Travel speed .....	High 0~5.5km/h (0~3.4mph) Low 0~3.9km/h (0~2.4mph)
Gradeability .....	70% (35°)
Max. drawbar pull.....	15,300kgf (33,700lbf)
Ground clearance (less grouser bar) .....	450mm (1'06")
Track length.....	3,640mm (11'11") HD-550V <sub>II</sub> 4,010mm (13'02") HD-550V <sub>II</sub> -LC



## HYDRAULIC SYSTEM

Two pumps are controlled by the Kato developed "APC" (Automatic Power Control) system, which senses where power is needed and automatically adjusts the pressure and flow-rate of the pump to match the work load. New "APC" system enables pump output to be utilized to the full with minimum fuel consumption. The adoption of joint circuit enables dual speed for boom derricking and arm extension/retraction/retraction.

Pumps.....	Variable double piston pump and gear pump
Max. discharge flow.....	2×172 lit./min. 2×45.4 US gal./min.
Max. discharge pressure .....	285kg/cm <sup>2</sup> (4,050 psi)
Max. discharge pressure (travel circuit only) .....	335kg/cm <sup>2</sup> (4,760 psi)
Oil filtration .....	One full-flow filter with replaceable element, a drain cartridge filter, a pilot line filter and a suction strainer
Control valves .....	3+4 section multiple control valves 2×logic valves (with service port)
Pilot pump .....	Gear type
Oil cooler.....	Finned tube, forced ventilation
Pressure relief valves.....	Primary and secondary on each circuit



## CAB & CONTROLS

The all-weather sound suppressed, 940mm (3'1") wide pressed steel cab is rubber mounted and has plenty of leg room. All windows are made of tinted safety glass. The front windscreen can be raised and slide back so that it fits flush with the ceiling to provide improved visibility and ventilation. The cloth-covered, fully adjustable seat is provided. Operating conditions can be seen at a glance on Safety Monitor.

Right hand lever .....	Controls the boom & bucket
Inner right hand lever (with foot pedal).....	Controls the right hand track
Inner left hand drive (with foot pedal).....	Controls the left hand track
Left hand lever .....	Controls the arm & swing
Pilot control.....	Boom, arm, bucket and swing
Engine throttle.....	Electric "Accel dial"
Safety monitor.....	Hour meter, water temperature and fuel level
Pilot lamps.....	Engine oil pressure, engine oil filter, hydraulic oil filter, hydraulic oil temperature, water temperature, water level, fuel level, battery charge and air cleaner
Standard cab accessories.....	Front screen wiper, adjustable reclining seat, cigarette lighter, ashtray, coat hook, floor mat, horn, internal light and storage compartment



Working lights..... Provided on the boom side and mounted on the frame  
 Lubrication chart..... Inside the cab  
 Tools..... Standard maintenance tools

Arm cylinder..... One, double acting  
 Bore & Stroke..... 120mm (4.7")×1,385mm (64.1")  
 Bucket cylinder..... One, double acting  
 Bore & Stroke..... 115mm (4.5")×920mm (36.2")  
 Lubrication..... Grease nipples, with centralized greasing for remote points  
 Bucket digging force..... 9,300kgf (20,500lbf)  
 Arm digging force.....7,000kgf (15,400lbf)



## SWING SYSTEM

The hydraulic gear-driven swing is powered by an axial piston motor that is flange-connected to a planetary reduction unit. It rotates 360° continuously on the single row-ball bearing that has an integral, internally cut swing gear, and is totally enclosed to prevent the ingress of mud and water.

**Brake**..... A hydraulic brake that locks automatically when the swing control lever is in the neutral position and a mechanical parking brake operated by either pulling the safety lock lever backwards or engine stop.

**Lubrication**..... Completely housed and grease bathed  
 Max. swing speed..... 13.4rpm  
 Tail swing radius.....2,470mm (8'01")  
 Min. front swing radius.....3,160mm (10'04")



## BOOM, ARM AND BUCKET

The boom and arm are of all-welded, steel box section type with reinforced pin joints. Bucket is fabricated from high tensile strength steel and use taper located teeth.  
**Boom cylinders**..... Two, double acting  
 Bore & Stroke..... 115mm (4.5")×1,190mm (46.9")



## REFILLING CAPACITY

Fuel tank..... 250 lit. (66 US gal.)  
 Cooling system..... 21 lit. (5.5 US gal.)  
 Engine oil..... 17 lit. (4.5 US gal.)  
 Track drives..... 2×3 lit. (2×0.8US gal.)  
 Swing drive..... 5 lit. (1.3 US gal.)  
**Hydraulic oil tank**  
 (level)..... 127 lit. (33.6US gal.)  
 (system)..... 225 lit. (59.4US gal.)



## WEIGHT

In standard figure, with the 2.57m(8'05") arm, 500mm (20") grouser shoes and 0.55m<sup>3</sup> CECE heaped (0.84 yd.<sup>3</sup> SAE heaped) bucket.

Operating weight....14,500kg (32,000lb) HD-550V<sub>II</sub>  
 15,700kg (34,600lb) HD-550V<sub>II</sub>-LC  
 Ground pressure ...0.46kgf/cm<sup>2</sup> (6.5psi) HD-550V<sub>II</sub>  
 0.38kgf/cm<sup>2</sup> (5.4psi) HD-550V<sub>II</sub>-LC

# Dimensions

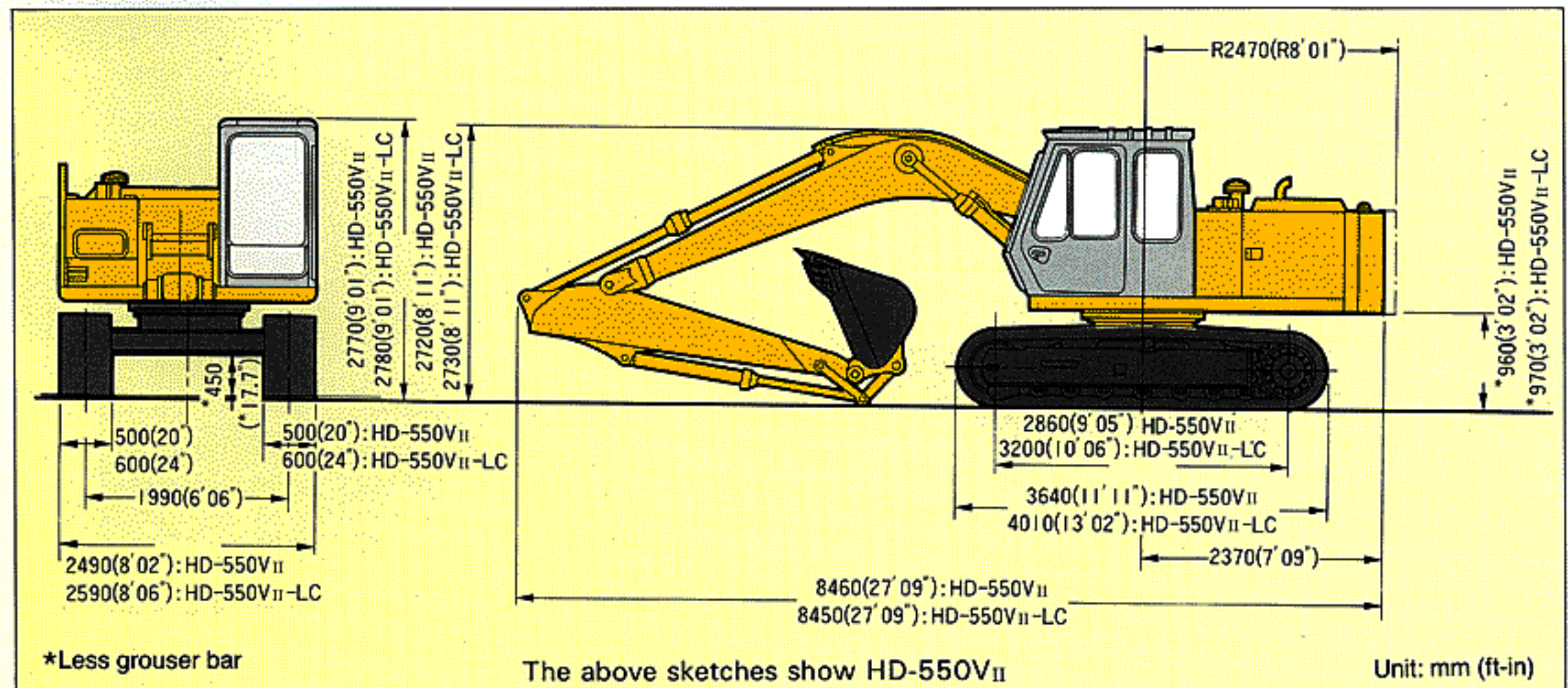







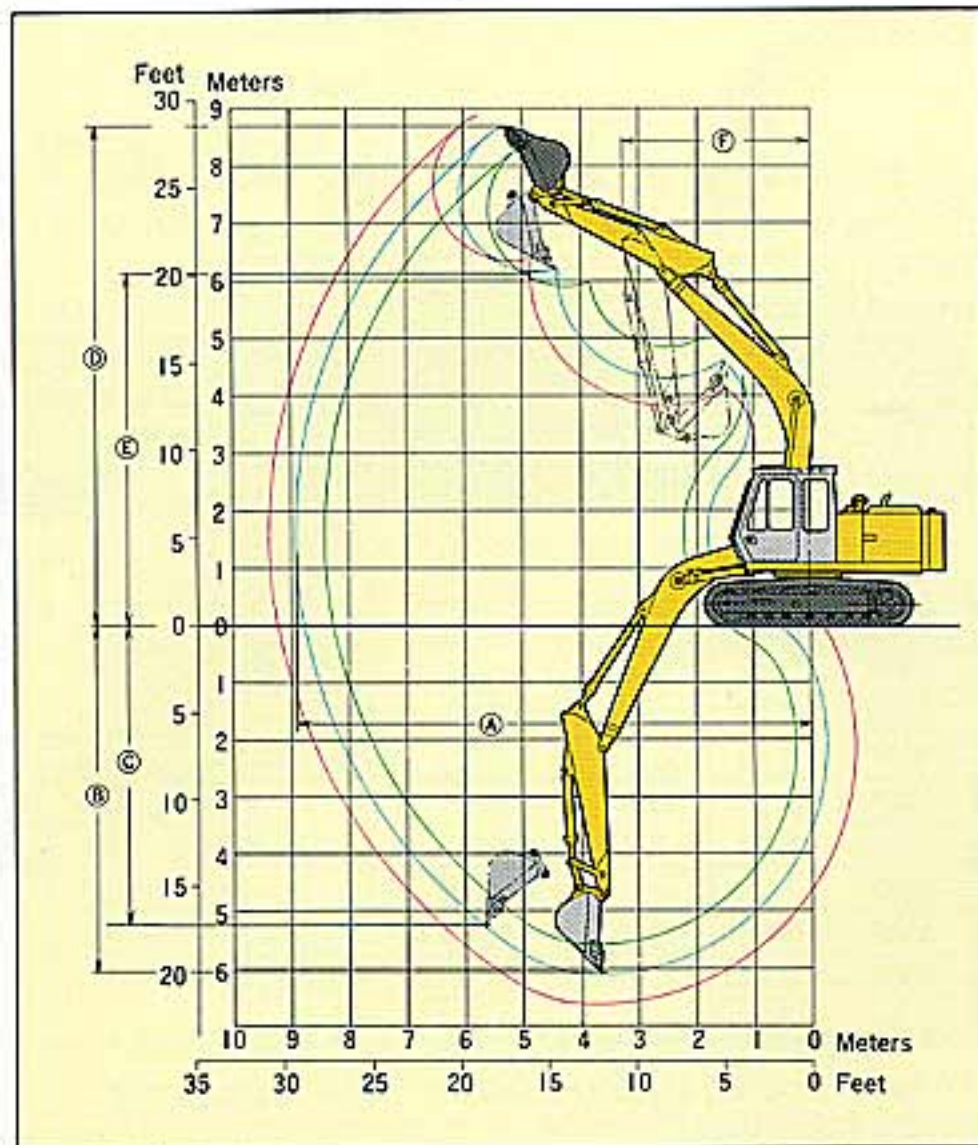

**HD-550V II**

Unit: m (ft-in)

Range	Arm	Short Arm 2.02(6'08")	STD Arm 2.57(8'05")	Long Arm 3.07(10'01")
Ⓐ- Max. digging radius		8.42(27'07")	8.91(29'03")	9.35(30'08")
Ⓑ- Max. digging reach at ground level		8.26(27'01")	8.75(28'08")	9.21(30'03")
Ⓒ- Max. digging depth		5.51(18'01")	6.06(19'11")	6.55(21'06")
Ⓓ- Max. digging height		8.46(27'09")	8.71(28'07")	8.91(29'03")
Ⓔ- Max. dumping height		5.91(19'05")	6.14(20'02")	6.34(20'10")
Ⓕ- Min. dumping height		2.78(9'01")	2.23(7'04")	1.74(5'09")
Ⓖ- Max. vertical wall		4.60(15'01")	5.25(17'03")	5.70(18'08")
Ⓗ- Min. swing radius		2.47(8'01")	2.47(8'01")	2.47(8'01")
Ⓘ- Max. digging depth (8 ft level bottom)		5.26(17'03")	5.84(19'02")	6.36(20'10")

\* Less grouser bar.

**HD-550V II-LC**

Unit: m (ft-in)

Range	Arm	Short Arm 2.02(6'08")	STD Arm 2.57(8'05")	Long Arm 3.07(10'01")
Ⓐ- Max. digging radius		8.42(27'07")	8.91(29'03")	9.35(30'08")
Ⓑ- Max. digging reach at ground level		8.26(27'01")	8.75(28'08")	9.21(30'03")
Ⓒ- Max. digging depth		5.50(18'01")	6.04(19'10")	6.54(21'05")
Ⓓ- Max. digging height		8.47(27'09")	8.72(28'07")	8.92(29'03")
Ⓔ- Max. dumping height		5.92(19'05")	6.15(20'02")	6.35(20'10")
Ⓕ- Min. dumping height		2.79(9'02")	2.24(7'04")	1.75(5'09")
Ⓖ- Max. vertical wall		4.58(15'00")	5.23(17'02")	5.69(18'08")
Ⓗ- Min. swing radius		2.47(8'01")	2.47(8'01")	2.47(8'01")
Ⓘ- Max. digging depth (8 ft level bottom)		5.25(17'03")	5.83(19'02")	6.35(20'10")

\* Less grouser bar.

**Bucket**

Type of bucket	Backhoe bucket					Rock bucket	Dredging bucket	Slope forming bucket	Grab bucket	Ripper
Bucket capacity m <sup>3</sup> , CECE m <sup>3</sup> (yd <sup>3</sup> ), PCSA(SAE)	0.26 0.28(0.37)	0.35 0.39(0.51)	0.45 0.51(0.67)	0.55 0.64(0.84)	0.65 0.76(0.99)	0.30 0.34(0.44)	0.40 0.46(0.60)	— —	0.45(0.59) (struck)	—
Bucket width	w/o side cutters mm(in)	540 (21')	690 (27')	840 (33')	990 (39')	1,140 (45')	735 (28.9')	45°	1,800(70.9')	815
	with side cutters mm(in)	630 (25')	780 (31')	930 (37')	1,080 (43')	1,230 (48')	845 (33.3')	300(11.8')	1,145(45.1')	(32.1)
Bucket weight	kg lb	360 840	430 950	480 1,060	530 1,170	580 1,280	690 1,520	450 990	505 1,110	680 1,500
Number of Bucket teeth	3	3	4	5	5	5	2	—	4+4	1
Shapes of bucket										
Standard boom +	Short arm	●	●	●	●	▲	⊙	●	○	●
	Standard arm	●	●	●	●	▲	⊙	●	○	●
	Long arm	●	●	●	▲	×	×	●	○	▲
	Extension arm	●	●	▲	×	×	×	▲	×	×

● General purpose ▲ Light work ⊙ Rock digging ○ Usable × Unusable  
● Yellow colored area means standard.

**Track Shoes**

Types of shoes	Grouser shoe				Flat shoe		Triangle shoe		
Shoe width	HD-550V II	500(20')	600(24')	700(28')	800(32')	500(20')	—	700(23')	800(32')
mm (in)	HD-550V II-LC	—	600(24')	700(28')	800(32')	—	600(24')	—	800(32')
Overall with	HD-550V II	2,490(8'02")	2,590(8'06")	2,690(8'10")	2,790(9'02")	2,490(8'02")	—	2,690(8'10")	2,790(9'02")
mm (in)	HD-550V II-LC	—	2,590(8'06")	2,690(8'10")	2,790(9'02")	—	2,590(8'06")	—	2,790(9'02")
Ground pressure	HD-550V II	0.46(6.54)	0.39(5.55)	0.34(4.83)	0.30(4.27)	0.47(6.68)	—	0.34(4.83)	0.30(4.27)
kgf/cm <sup>2</sup> (psi)	HD-550V II-LC	—	0.37(5.26)	0.33(4.69)	0.29(4.12)	—	0.39(5.55)	—	0.29(4.12)
Net weight change	HD-550V II	STD	+190(420)	+390(860)	+765(1,690)	+320(710)	—	+640(1,410)	+830(1,830)
kg (lb)	HD-550V II-LC	—	STD	+230(510)	+460(1,010)	—	+580(1,280)	—	+320(710)

● Yellow colored area means standard.

**Extension Arm**

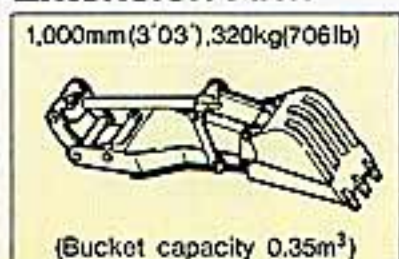

- Options:
- APC system (APC, Auto-Slow)
  - Pre-cleaner and Double element for air cleaner
  - Electric refueling pump
  - 24V-5.5kW Starter motor
  - 24V-40A Alternator
  - Hydraulic piping for breaker
  - Hydraulic piping for spare port
  - Radio
  - Room fan
  - Room heater
  - Air-conditioner



# LIFTING CAPACITIES

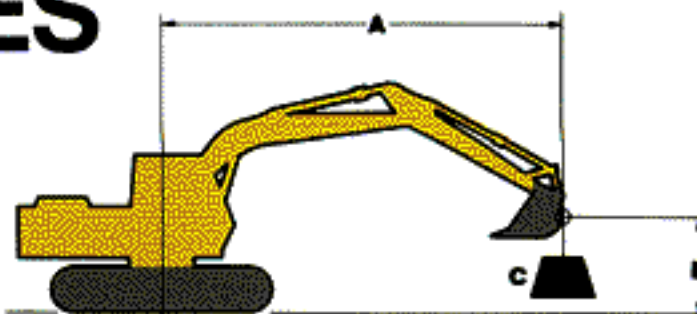

A: REACH FROM SWING CENTERLINE  
 B: BUCKET HOOK HEIGHT  
 C: LIFTING CAPACITIES

: OVER FRONT  
 : OVER SIDE OR 360°

## HD-550V<sub>II</sub> 5.10m Boom 2.02m Arm

Equipped with 500mm Shoes and 0.55m<sup>3</sup> (CECE heaped) Bucket

Unit:1000kg

LOAD POINT HEIGHT B m	LOAD RADIUS A m												MAXIMUM LOAD RADIUS			
	2.00		3.00		4.00		5.00		6.00		7.00				m	
7.00														*2.72	*2.72	5.93
6.00							*3.04	*3.04						*2.56	2.19	6.78
5.00							*3.13	*3.13	*3.23	2.66				*2.50	1.85	7.36
4.00					*3.96	*3.96	*3.57	3.55	*3.40	2.62				2.32	1.66	7.75
3.00					*5.28	4.80	*4.24	3.40	3.53	2.54	2.72	1.94		2.18	1.54	7.97
2.00					6.53	4.49	4.58	3.24	3.43	2.45	2.67	1.90		2.11	1.49	8.04
1.00					*5.05	4.30	4.44	3.11	3.34	2.37	2.62	1.85		2.12	1.48	7.97
0.00					6.22	4.22	4.35	3.03	3.28	2.30	2.58	1.81		2.20	1.54	7.74
-1.00					6.20	4.20	4.30	2.99	3.24	2.27	2.56	1.79		2.38	1.67	7.35
-2.00	*3.44	*3.44	*7.09	6.80	6.21	4.21	4.30	2.98	3.23	2.26				2.73	1.92	6.76
-3.00	*7.92	*7.92	*8.66	6.87	6.26	4.26	4.33	3.01	3.27	2.30						
-4.00			*7.82	6.99	*6.25	4.35	4.43	3.10								

## HD-550V<sub>II</sub> 5.10m Boom 2.57m Arm

Equipped with 500mm Shoes and 0.55m<sup>3</sup> (CECE heaped) Bucket

Unit:1000 kg

LOAD POINT HEIGHT B m	LOAD RADIUS A m												MAXIMUM LOAD RADIUS				
	2.00		3.00		4.00		5.00		6.00		7.00		8.00				m
7.00															*2.13	*2.13	6.60
6.00															*2.02	1.89	7.36
5.00									*2.75	2.70					*1.98	1.63	7.90
4.00							*3.06	*3.06	*2.98	2.65	2.78	2.00			*1.97	1.47	8.25
3.00			*6.13	*6.13	*4.44	*4.44	*3.73	3.46	*3.37	2.56	2.73	1.95			1.96	1.37	8.46
2.00					*5.88	4.61	*4.52	3.28	3.45	2.46	2.67	1.90			1.90	1.32	8.52
1.00					6.38	4.35	4.47	3.13	3.35	2.36	2.61	1.84	2.08	1.45	1.90	1.31	8.45
0.00					6.22	4.21	4.34	3.02	3.26	2.29	2.56	1.79			1.96	1.36	8.24
-1.00			*3.76	*3.76	6.15	4.15	4.27	2.96	3.21	2.24	2.52	1.75			2.10	1.45	7.88
-2.00	*3.89	*3.89	*6.92	6.66	6.14	4.14	4.24	2.93	3.19	2.22	2.51	1.75			2.35	1.64	7.34
-3.00	*6.33	*6.33	*9.87	6.72	6.17	4.17	4.26	2.94	3.20	2.23					2.83	1.99	6.57
-4.00	*9.46	*9.46	*8.80	6.82	6.25	4.24	4.31	2.99							*2.85	2.73	5.45
-5.00					*5.38	4.38											

## HD-550V<sub>II</sub> 5.10m Boom 3.07m Arm

Equipped with 500mm Shoes and 0.55m<sup>3</sup> (CECE heaped) Bucket

Unit:1000kg

LOAD POINT HEIGHT B m	LOAD RADIUS A m												MAXIMUM LOAD RADIUS						
	1.00		2.00		3.00		4.00		5.00		6.00		7.00		8.00				m
8.00																	*1.91	*1.91	6.21
7.00																	*1.75	*1.75	7.19
6.00																	*1.66	1.66	7.89
5.00											*2.34	*2.34	*2.54	2.05			*1.63	1.44	8.38
4.00											*2.60	*2.60	*2.65	2.02			*1.63	1.30	8.72
3.00									*3.24	*3.24	*3.00	2.58	2.74	1.96	2.15	1.51	*1.66	1.22	8.91
2.00							*5.09	4.70	*4.04	3.32	3.47	2.47	2.67	1.89	2.11	1.47	1.71	1.17	8.97
1.00							*6.41	4.39	4.48	3.14	3.35	2.36	2.60	1.82	2.06	1.43	1.71	1.17	8.91
0.00					*2.49	*2.49	6.21	4.19	4.33	3.00	3.25	2.27	2.53	1.76	2.02	1.39	1.76	1.20	8.71
-1.00			*1.66	*1.66	*4.10	*4.10	6.09	4.09	4.23	2.91	3.17	2.20	2.48	1.72	2.00	1.37	1.87	1.27	8.37
-2.00	*2.71	*2.71	*3.78	*3.78	*6.32	*6.32	6.05	4.05	4.18	2.87	3.13	2.16	2.46	1.69			2.06	1.42	7.87
-3.00	*4.87	*4.87	*6.27	*6.27	*9.38	*6.54	6.06	4.06	4.18	2.86	3.13	2.16	2.47	1.70			2.41	1.67	7.16
-4.00			*9.37	*9.37	*9.46	*6.64	6.12	4.11	4.21	2.90	3.16	2.19					3.10	2.17	6.17
-5.00					*8.03	*6.80	*6.21	4.22	4.32	2.99									

**NOTE:**

- Lifting capacities are based on SAE J1097.
- Lifting capacities shown do not exceed 87% of machine hydraulic capacity or 75% of minimum tipping load.
- Capacities marked with an asterisk(\*) are limited by hydraulic capacities.
- Lifting capacities are based on machine standing on firm, uniform supporting surface. User must make allowances for job conditions such as soft or uneven ground.
- Lifting capacities shown should not be exceeded. Weight of all lifting accessories must be deducted from the above lifting capacities.
- Capacities apply only to the machine as originally manufactured and equipped by KATO WORKS CO., LTD.



**HD-550V<sub>II</sub>-LC 5.10m Boom 2.02m Arm**

**Equipped with 600mm Shoes and 0.55m<sup>3</sup>(CECE heaped) Bucket**

Unit:1000kg

LOAD POINT HEIGHT B m	LOAD RADIUS A m												MAXIMUM LOAD RADIUS			
	2.00		3.00		4.00		5.00		6.00		7.00		m	m	m	
7.00														*2.72	*2.72	5.93
6.00							*3.04	*3.04						*2.56	2.44	6.78
5.00							*3.13	*3.13	*3.23	2.95				*2.50	2.08	7.36
4.00					*3.96	*3.96	*3.57	*3.57	*3.40	2.91				*2.48	1.87	7.75
3.00					*5.28	*5.28	*4.24	3.77	*3.75	2.83	3.40	2.18		*2.52	1.74	7.97
2.00					*6.72	5.00	*4.99	3.61	*4.18	2.74	3.35	2.13		*2.61	1.69	8.04
1.00					*5.05	4.81	5.62	3.48	4.21	2.65	3.30	2.08		2.69	1.69	7.97
0.00					*6.52	4.73	5.52	3.40	4.14	2.59	3.26	2.05		2.79	1.75	7.74
-1.00					7.99	4.71	5.47	3.36	4.10	2.56	3.24	2.03		3.02	1.90	7.35
-2.00	*3.44	*3.44	*7.03	*7.03	*7.81	4.72	5.46	3.35	4.09	2.55				3.45	2.17	6.76
-3.00	*7.85	*7.85	*8.66	7.69	*7.28	4.77	5.50	3.38	4.14	2.59						
-4.00			*7.82	7.81	*6.25	4.86	*4.81	3.47								

**HD-550V<sub>II</sub>-LC 5.10m Boom 2.57m Arm**

**Equipped with 600mm Shoes and 0.55m<sup>3</sup>(CECE heaped) Bucket**

Unit:1000kg

LOAD POINT HEIGHT B m	LOAD RADIUS A m												MAXIMUM LOAD RADIUS				
	2.00		3.00		4.00		5.00		6.00		7.00		8.00		m	m	m
7.00															*2.13	*2.13	6.60
6.00															*2.02	*2.02	7.36
5.00								*2.75	*2.75						*1.98	1.83	7.90
4.00							*3.06	*3.06	*2.98	2.94	*3.00	2.24			*1.97	1.66	8.25
3.00			*6.13	*6.13	*4.44	*4.44	*3.73	*3.73	*3.37	2.85	*3.20	2.19			*2.01	1.56	8.46
2.00					*5.88	5.12	*4.52	3.66	*3.84	2.75	3.36	2.13			*2.08	1.51	8.52
1.00					*7.06	4.86	*5.25	3.50	4.22	2.65	3.29	2.07	*2.61	1.65	*2.20	1.50	8.45
0.00					*7.74	4.72	5.52	3.39	4.13	2.58	3.24	2.02			*2.38	1.55	8.24
-1.00			*3.76	*3.76	7.94	4.66	5.44	3.32	4.07	2.53	3.20	1.99			*2.64	1.66	7.88
-2.00	*3.89	*3.89	*6.92	*6.92	7.93	4.65	5.41	3.30	4.05	2.50	3.19	1.98			2.99	1.86	7.34
-3.00	*6.33	*6.33	*9.87	7.54	*7.60	4.68	5.42	3.31	4.06	2.51					3.58	2.24	6.57
-4.00	*9.46	*9.46	*8.80	7.65	*6.88	4.75	*5.44	3.36							*2.85	*2.85	5.45
-5.00					*5.38	4.89											

**HD-550V<sub>II</sub>-LC 5.10m Boom 3.07m Arm**

**Equipped with 600mm Shoes and 0.55m<sup>3</sup>(CECE heaped) Bucket**

Unit:1000kg

LOAD POINT HEIGHT B m	LOAD RADIUS A m														MAXIMUM LOAD RADIUS						
	1.00		2.00		3.00		4.00		5.00		6.00		7.00		8.00		m	m	m		
8.00																		*1.91	*1.91	6.21	
7.00																		*1.75	*1.75	7.19	
6.00																		*1.66	*1.66	7.89	
5.00										*2.34	*2.34	*2.54	2.29					*1.63	*1.63	8.38	
4.00										*2.60	*2.60	*2.65	2.25					*1.63	1.49	8.72	
3.00								*3.24	*3.24	*3.00	2.87	*2.88	2.20	*2.55	1.71	*1.66	1.40	*1.66	1.40	8.91	
2.00						*5.09	*5.09	*4.04	3.69	*3.49	2.76	*3.18	2.13	2.67	1.67	*1.72	1.35	*1.72	1.35	8.97	
1.00						*6.41	4.91	*4.83	3.51	*4.00	2.65	3.28	2.06	2.63	1.63	*1.82	1.34	*1.82	1.34	8.91	
0.00					*2.49	*2.49	*7.31	4.70	*5.48	3.37	4.11	2.56	3.22	2.00	2.59	1.59	*1.97	1.38	*1.97	1.38	8.71
-1.00			*1.66	*1.66	*4.10	*4.10	*7.78	4.60	5.40	3.28	4.04	2.49	3.17	1.95	2.56	1.57	*2.17	1.46	*2.17	1.46	8.37
-2.00	*2.71	*2.71	*3.78	*3.78	*6.32	*6.32	7.83	4.56	5.35	3.23	4.00	2.45	3.14	1.93			*2.48	1.62	*2.48	1.62	7.87
-3.00	*4.87	*4.87	*6.27	*6.27	*9.38	7.36	*7.74	4.57	5.34	3.23	3.99	2.44	3.15	1.94			*2.98	1.90	*2.98	1.90	7.16
-4.00			*9.37	*9.37	*9.46	7.46	*7.24	4.62	5.38	3.26	4.03	2.48					*3.58	2.45	*3.58	2.45	6.17
-5.00					*8.03	7.62	*6.21	4.73	*4.79	3.36											

**NOTE:**

- 1) Lifting capacities are based on SAE J1097.
- 2) Lifting capacities shown do not exceed 87% of machine hydraulic capacity or 75% of minimum tipping load.
- 3) Capacities marked with an asterisk(\*) are limited by hydraulic capacities.
- 4) Lifting capacities are based on machine standing on firm, uniform supporting surface. User must make allowances for job conditions such as soft or uneven ground.
- 5) Lifting capacities shown should not be exceeded. Weight of all lifting accessories must be deducted from the above lifting capacities.
- 6) Capacities apply only to the machine as originally manufactured and equipped by KATO WORKS CO., LTD.



**HD-550V<sub>II</sub> 5.10m(16'09") Boom 2.02m(6'08") Arm**  
**Equipped with 500mm(20") Shoes and 0.64m<sup>3</sup>(0.84yd<sup>3</sup>) (PCSA heaped) Bucket**

Unit : 1000 lb  
(1000 kg)

LOAD POINT HEIGHT B ft. in. (m)	LOAD RADIUS A ft.in.(m)						MAXIMUM LOAD RADIUS		
	10'0" (3.05)		15'0" (4.57)		20'0" (6.10)		ft.in. (m)	ft.in. (m)	ft.in. (m)
25'0" (7.62)							*6.41 (2.91)	*6.41 (2.91)	17'0" (5.19)
20'0" (6.10)							*5.68 (2.58)	4.92 (2.23)	22'0" (6.71)
15'0" (4.57)			*7.34 (3.33)	*7.34 (3.33)	*7.23 (3.28)	5.68 (2.57)	5.40 (2.45)	3.87 (1.76)	24'9" (7.55)
10'0" (3.05)			*10.01 (4.54)	9.57 (3.92)	7.59 (3.44)	5.46 (2.47)	4.81 (2.18)	3.40 (1.54)	26'1" (7.96)
5'0" (1.52)			11.44 (5.19)	7.98 (3.62)	7.28 (3.30)	5.17 (2.35)	4.65 (2.11)	3.26 (1.48)	26'4" (8.02)
0'0" (0.00)			11.04 (5.01)	7.62 (3.46)	7.05 (3.20)	4.96 (2.25)	4.85 (2.20)	3.40 (1.54)	25'5" (7.74)
-5'0" (-1.52)	*11.39 (5.17)	*11.39 (5.17)	10.93 (4.96)	7.53 (3.42)	6.95 (3.15)	4.87 (2.21)	5.60 (2.54)	3.93 (1.78)	23'2" (7.07)
-10'0" (-3.05)	*19.84 (9.00)	*14.73 (6.68)	11.03 (5.00)	7.62 (3.46)			*7.25 (3.29)	5.41 (2.45)	19'2" (5.84)

**HD-550V<sub>II</sub> 5.10m(16'09") Boom 2.57m(8'05") Arm**  
**Equipped with 500mm(20") Shoes and 0.64m<sup>3</sup>(0.84yd<sup>3</sup>) (PCSA heaped) Bucket**

Unit : 1000 lb  
(1000 kg)

LOAD POINT HEIGHT B ft. in. (m)	LOAD RADIUS A ft. in. (m)								MAXIMUM LOAD RADIUS				
	5'0" (1.52)		10'0" (3.05)		15'0" (4.57)		20'0" (6.10)		25'0" (7.62)		ft.in. (m)	ft.in. (m)	ft.in. (m)
25'0" (7.62)											*4.97 (2.25)	*4.97 (2.25)	19'7" (5.96)
20'0" (6.10)											*4.48 (2.03)	4.24 (1.93)	23'11" (7.30)
15'0" (4.57)							*6.25 (2.84)	5.75 (2.61)			*4.34 (1.97)	3.42 (1.55)	26'6" (8.07)
10'0" (3.05)			*12.89 (5.85)	*12.89 (5.85)	*8.67 (3.93)	*8.67 (3.93)	*7.34 (3.33)	5.50 (2.50)	5.17 (2.35)	3.67 (1.66)	4.32 (1.96)	3.02 (1.37)	27'9" (8.45)
5'0" (1.52)					11.57 (5.25)	8.09 (3.67)	7.30 (3.31)	5.19 (2.35)	5.04 (2.28)	3.54 (1.60)	4.17 (1.89)	2.89 (1.31)	27'11" (8.51)
0'0" (0.00)					11.03 (5.00)	7.61 (3.45)	7.02 (3.18)	4.92 (2.23)	4.91 (2.23)	3.41 (1.55)	4.32 (1.96)	2.99 (1.36)	27'1" (8.24)
-5'0" (-1.52)			*12.22 (5.54)	12.22 (5.54)	10.83 (4.91)	7.42 (3.37)	6.87 (3.11)	4.78 (2.17)	4.88 (2.21)	3.39 (1.54)			
-10'0" (-3.05)	*14.41 (6.53)	*14.41 (6.53)	*21.39 (9.70)	14.41 (6.54)	10.86 (4.92)	7.45 (3.38)	6.88 (3.12)	4.80 (2.17)			6.31 (2.86)	4.43 (2.01)	21'5" (6.53)
-15'0" (-4.57)			*17.17 (7.79)	14.83 (6.73)	11.15 (5.06)	7.71 (3.50)							

**HD-550V<sub>II</sub> 5.10m(16'09") Boom 3.07m(10'01") Arm**  
**Equipped with 500mm(20") Shoes and 0.64m<sup>3</sup>(0.84yd<sup>3</sup>) (PCSA heaped) Bucket**

Unit : 1000 lb  
(1000 kg)

LOAD POINT HEIGHT B ft. in. (m)	LOAD RADIUS A ft. in. (m)								MAXIMUM LOAD RADIUS				
	5'0" (1.52)		10'0" (3.05)		15'0" (4.57)		20'0" (6.10)		25'0" (7.62)		ft.in. (m)	ft.in. (m)	ft.in. (m)
25'0" (7.62)											*4.04 (1.83)	*4.04 (1.83)	21'9" (6.62)
20'0" (6.10)							*5.12 (2.32)	*5.12 (2.32)			*3.68 (1.67)	*3.68 (1.67)	25'8" (7.83)
15'0" (4.57)							*5.38 (2.44)	*5.38 (2.44)	*4.84 (2.19)	3.77 (1.71)	*3.58 (1.62)	3.04 (1.38)	28'0" (8.54)
10'0" (3.05)					*7.37 (3.34)	*7.37 (3.34)	*6.53 (2.96)	5.55 (2.52)	5.19 (2.35)	3.68 (1.67)	*3.65 (1.66)	2.69 (1.22)	29'2" (8.90)
5'0" (1.52)					*10.76 (4.88)	8.18 (3.71)	7.32 (3.32)	5.19 (2.35)	5.02 (2.28)	3.51 (1.59)	3.76 (1.71)	2.57 (1.16)	29'5" (8.96)
0'0" (0.00)			*5.95 (2.70)	*5.95 (2.70)	11.01 (4.99)	7.57 (3.43)	6.98 (3.16)	4.87 (2.21)	4.85 (2.20)	3.35 (1.52)	3.87 (1.76)	2.64 (1.20)	28'7" (8.71)
-5'0" (-1.52)	*4.68 (2.12)	*4.68 (2.12)	*11.82 (5.36)	*11.82 (5.36)	10.69 (4.85)	7.29 (3.31)	6.77 (3.07)	4.68 (2.12)	4.75 (2.15)	3.26 (1.48)	4.31 (1.96)	2.95 (1.34)	26'8" (8.13)
-10'0" (-3.05)	*12.39 (5.62)	*12.39 (5.62)	*21.63 (9.81)	14.04 (6.37)	10.65 (4.83)	7.25 (3.29)	6.73 (3.05)	4.64 (2.10)			5.37 (2.44)	3.72 (1.69)	23'5" (7.12)
-15'0" (-4.57)			*19.00 (8.62)	14.41 (6.54)	10.86 (4.93)	7.44 (3.37)					*6.22 (2.82)	6.00 (2.72)	17'9" (5.40)

- NOTE:
- 1) Lifting capacities are based on SAE J1097.
  - 2) Lifting capacities shown do not exceed 87% of machine hydraulic capacity or 75% of minimum tipping load.
  - 3) Capacities marked with an asterisk(\*) are limited by hydraulic capacities.
  - 4) Lifting capacities are based on machine standing on firm, uniform supporting surface. User must make allowances for job conditions such as soft or uneven ground.
  - 5) Lifting capacities shown should not be exceeded. Weight of all lifting accessories must be deducted from the above lifting capacities.
  - 6) Capacities apply only to the machine as originally manufactured and equipped by KATO WORKS CO., LTD.



**HD-550<sub>II</sub>-LC 5.10m(16'09") Boom 2.02m(6'08") Arm**  
**Equipped with 600mm(24") Shoes and 0.64m<sup>3</sup>(0.84yd<sup>3</sup>) (PCSA heaped) Bucket**

Unit : 1000 lb  
(1000 kg)

LOAD POINT HEIGHT B ft. in. (m)	LOAD RADIUS A ft. in. (m)						MAXIMUM LOAD RADIUS		
	10'0" (3.05)		15'0" (4.57)		20'0" (6.10)		ft. in. (m)	ft. in. (m)	ft. in. (m)
25'0" (7.62)							* 6.41 (2.91)	* 6.41 (2.91)	17'0" (5.19)
20'0" (6.10)							* 5.68 (2.58)	5.47 (2.48)	22'0" (6.71)
15'0" (4.57)			* 7.34 (3.33)	* 7.34 (3.33)	* 7.23 (3.28)	6.30 (2.86)	* 5.48 (2.48)	4.35 (1.97)	24'9" (7.55)
10'0" (3.05)			* 10.01 (4.54)	9.57 (4.34)	* 8.16 (3.70)	6.08 (2.76)	* 5.56 (2.52)	3.85 (1.75)	26'1" (7.96)
5'0" (1.52)			* 13.16 (5.97)	8.91 (4.04)	9.15 (4.15)	5.80 (2.63)	5.88 (2.67)	3.70 (1.68)	26'4" (8.02)
0'0" (0.00)			14.07 (6.38)	8.54 (3.88)	8.90 (4.04)	5.58 (2.53)	6.15 (2.79)	3.66 (1.75)	25'5" (7.74)
-5'0" (-1.52)	* 11.39 (5.17)	* 11.39 (5.17)	13.96 (6.33)	8.45 (3.83)	8.80 (3.99)	5.49 (2.49)	7.08 (3.21)	4.45 (2.02)	23'2" (7.07)
-10'0" (-3.05)	* 19.84 (9.00)	16.50 (7.48)	* 14.06 (6.38)	8.54 (3.87)			* 7.25 (3.29)	6.07 (2.75)	19'2" (5.84)

**HD-550<sub>II</sub>-LC 5.10m(16'09") Boom 2.57m(8'05") Arm**  
**Equipped with 600mm(24") Shoes and 0.64m<sup>3</sup>(0.84yd<sup>3</sup>) (PCSA heaped) Bucket**

Unit : 1000 lb  
(1000 kg)

LOAD POINT HEIGHT B ft. in. (m)	LOAD RADIUS A ft. in. (m)								MAXIMUM LOAD RADIUS				
	5'0" (1.52)		10'0" (3.05)		15'0" (4.57)		20'0" (6.10)		25'0" (7.62)		ft. in. (m)	ft. in. (m)	ft. in. (m)
25'0" (7.62)											* 4.97 (2.25)	* 4.97 (2.25)	19'7" (5.96)
20'0" (6.10)											* 4.48 (2.03)	* 4.48 (2.03)	23'11" (7.30)
15'0" (4.57)							* 6.25 (2.84)	* 6.25 (2.84)			* 4.34 (1.97)	3.86 (1.75)	26'6" (8.07)
10'0" (3.05)			* 12.89 (5.85)	* 12.89 (5.85)	* 8.67 (3.93)	* 8.67 (3.93)	* 7.34 (3.33)	6.13 (2.78)	6.51 (2.95)	4.14 (1.88)	* 4.42 (2.01)	3.44 (1.55)	27'9" (8.45)
5'0" (1.52)					* 11.97 (5.43)	9.02 (4.09)	* 8.84 (4.01)	5.81 (2.64)	6.37 (2.89)	4.01 (1.82)	* 4.70 (2.13)	3.30 (1.50)	27'11" (8.51)
0'0" (0.00)					14.08 (6.38)	8.53 (3.87)	8.88 (4.03)	5.54 (2.51)	6.24 (2.83)	3.88 (1.76)	* 5.24 (2.38)	3.41 (1.55)	27'1" (8.24)
-5'0" (-1.52)			* 12.22 (5.54)	* 12.22 (5.54)	13.86 (6.29)	8.35 (3.79)	8.72 (3.96)	5.40 (2.45)	6.21 (2.82)	3.86 (1.75)			
-10'0" (-3.05)	* 14.41 (6.53)	* 14.41 (6.53)	* 21.39 (9.70)	16.18 (7.34)	13.89 (6.30)	8.37 (3.80)	8.74 (3.96)	5.42 (2.46)			7.99 (3.62)	5.00 (2.27)	21'5" (6.53)
-15'0" (-4.57)			* 17.17 (7.79)	16.60 (7.53)	* 11.79 (5.35)	8.63 (3.91)							

**HD-550<sub>II</sub>-LC 5.10m(16'09") Boom 3.07m(10'01") Arm**  
**Equipped with 600mm(24") Shoes and 0.64m<sup>3</sup>(0.84yd<sup>3</sup>) (PCSA heaped) Bucket**

Unit : 1000 lb  
(1000 kg)

LOAD POINT HEIGHT B ft. in. (m)	LOAD RADIUS A ft. in. (m)								MAXIMUM LOAD RADIUS				
	5'0" (1.52)		10'0" (3.05)		15'0" (4.57)		20'0" (6.10)		25'0" (7.62)		ft. in. (m)	ft. in. (m)	ft. in. (m)
25'0" (7.62)											* 4.04 (1.83)	* 4.04 (1.83)	21'9" (6.62)
20'0" (6.10)							* 5.12 (2.32)	* 5.12 (2.32)			* 3.68 (1.67)	* 3.68 (1.67)	25'8" (7.83)
15'0" (4.57)							* 5.38 (2.44)	* 5.38 (2.44)	* 4.84 (2.19)	4.24 (1.92)	* 3.58 (1.62)	3.45 (1.56)	28'0" (8.54)
10'0" (3.05)					* 7.37 (3.34)	* 7.37 (3.34)	* 6.53 (2.96)	6.18 (2.80)	* 6.27 (2.84)	4.15 (1.88)	* 3.65 (1.66)	3.08 (1.40)	29'2" (8.90)
5'0" (1.52)					* 10.76 (4.88)	9.11 (4.13)	* 8.13 (3.69)	5.82 (2.64)	6.35 (2.88)	3.98 (1.81)	* 3.89 (1.76)	2.95 (1.34)	29'5" (8.96)
0'0" (0.00)			* 5.95 (2.70)	* 5.95 (2.70)	* 13.51 (6.13)	8.50 (3.85)	8.84 (4.01)	5.49 (2.49)	6.18 (2.80)	3.82 (1.73)	* 4.33 (1.97)	3.04 (1.38)	28'7" (8.71)
-5'0" (-1.52)	* 4.68 (2.12)	* 4.68 (2.12)	* 11.82 (5.36)	* 11.82 (5.36)	13.73 (6.23)	8.21 (3.72)	8.62 (3.91)	5.30 (2.40)	6.08 (2.76)	3.73 (1.69)	* 5.12 (2.32)	3.38 (1.53)	26'8" (8.13)
-10'0" (-3.05)	* 12.39 (5.62)	* 12.39 (5.62)	* 21.63 (9.81)	15.80 (7.17)	13.68 (6.21)	8.17 (3.71)	8.58 (3.89)	5.26 (2.39)			* 6.64 (3.01)	4.23 (1.92)	23'5" (7.12)
-15'0" (-4.57)			* 19.00 (8.62)	16.18 (7.34)	* 12.95 (5.87)	8.36 (3.79)					* 6.22 (2.82)	* 6.22 (2.82)	17'9" (5.40)

**NOTE:**

- 1) Lifting capacities are based on SAE J1097.
- 2) Lifting capacities shown do not exceed 87% of machine hydraulic capacity or 75% of minimum tipping load.
- 3) Capacities marked with an asterisk(\*) are limited by hydraulic capacities.
- 4) Lifting capacities are based on machine standing on firm, uniform supporting surface.  
User must make allowances for job conditions such as soft or uneven ground.
- 5) Lifting capacities shown should not be exceeded. Weight of all lifting accessories must be deducted from the above lifting capacities.
- 6) Capacities apply only to the machine as originally manufactured and equipped by KATO WORKS CO., LTD.



Address inquiries to:

• NOTE: Illustrations may include optional equipment. KATO products and specifications are subject to improvements and changes without notice.

**KATO**

**QUALITY & EXPERIENCE  
SINCE 1895**

**KATO WORKS CO.,LTD.**

9-37, Higashi-ohi 1-chome, Shinagawa-ku, Tokyo 140, Japan.

Tel. : Head Office Tokyo (03)3458-1111

Overseas Marketing Department Tokyo (03)3458-1115

Telex : 222-4519 (CRKATO J)

Fax. : Tokyo (03)3458-1152

Cable : CRANEKATO TOKYO